

Add: 10-2-101 Fenghexinyuan Nankai District Tianjin China  
 Tel:+86 22 87348386 Web:www.newroc-phe.com E-mail:info@newroc-phe.com

## New Design High Efficiency Counterflow Plate Heat Exchanger

Heat exchangers are typically classified according to flow arrangement and type of construction. The simplest heat exchanger is one for which the hot and cold fluids move in the same or opposite directions. **Our high quality standards apply to Counter-flow Plate Heat Exchangers as with all our products.**

Counterflow this means that as the hot fluid enters from the right, it cools against the already warmed up cold fluid from the left. The temperature differential is nowhere near as high as at the start of the parallel heat exchanger. However, as the temperature of the warm fluids drops, it gets exposed to even colder cool fluid. Under comparable conditions, **more heat is transferred in a counter-flow arrangement than in a parallel flow heat exchanger.**

Professional plate heat exchanger manufacturer We can not only provide you with PHE, but also we can design the appropriate plan for heating exchange according to your need. **We have 15- year experience of designing in this field and solve various problems for you.** We have a wealth of HVAC, refrigeration, metal steel, marine engineering, paper, power, chemical, marine engineering, food and beverage experience.

### Our Advantages:

1. Manufacturer and Distributer, we can supply different brands and series plate and gasket, such as Alfa-Lava, APV, GEA, Tranter, SONDEX etc.
2. As manufacturer, we can supply the best quality replace parts for above brands to help you save more cost.
3. Over 15 years' experience in the energy field, we also can provided technical service such as technical consultation, equipment upgrade, capacity expansion scheme, maintenance and cleaning of the equipment.
4. High quality with competitive price, global fast delivery.
5. Our products are superior quality and environment friendly.
6. Prompt response to inquiries and orders.
7. Inventory for standard products.

### Working principles

Heat exchanger is an equipment which reduces the temperature of a medium by transferring temperature of that medium to another, when both the mediums are separated by a solid membrane or wall like structure. For efficient operation, the surface area of the wall which separates the two mediums is maximized, simultaneously minimizing the flow resistance of the

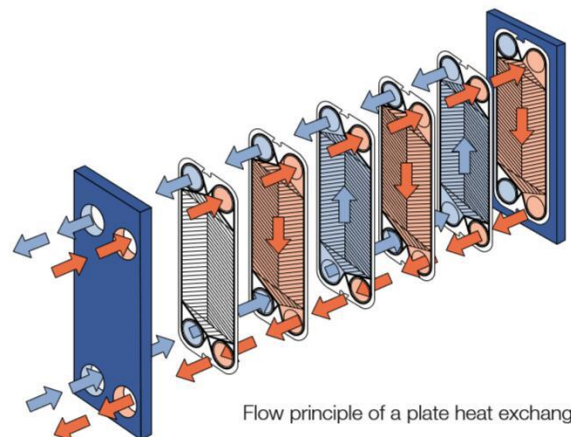
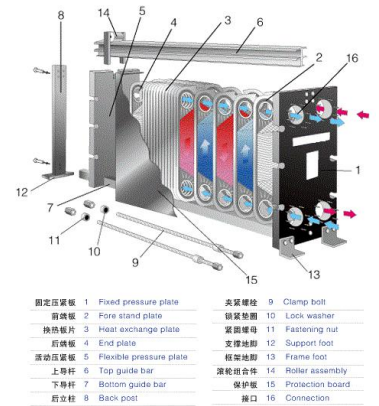

Flow principle of a plate heat exchanger

fluid.Channels are formed between the plates and corner ports are arranged so that the two media flow through alternate channels. The heat is transferred through the thin plate between the channels, and complete counter current flow is created for highest possible efficiency.No intermixing of the media or leakage to the surroundings will take place as gaskets around the edges of the plates seal the unit. The corrugation of the plates provides a suitable passage between the plates, support of each plate against the adjacent one and a strong turbulence resulting in maximum heat transfer efficiency.

### Standard Materials

For Frame: Carbon steel, stainless steel,

For Plate: Stainless steel ,titanium Plates Stainless steel alloy304,Stainless steel alloy316 Stainless steel alloy C276 or Titanium or SMO

For Gaskets: NBR , EPDM , Viton A, Viton G CR

### Why choose Gasketed Plate Heat Exchanger?

- \* High heat transfer efficiency
- \* Low pressure lose
- \* Compact structure
- \* Easy assembly & disassembly
- \* Sensitive temperature control
- \* High operating flexibility
- \* Long life-time

### Application

Food industry: Milk pasteurization Milk and beverage pasteurization, Wine tempering, Bottled water treatment, CIP (Cleaning-in-Place) heating, Reverse osmosis water.

Marine application: Central cooling of the main or auxiliary engines or turbines, Lubrication oil cooling, Recooling of circulated water for cooling cylinders, pistons, injection nozzles, Cooling of Baoder oil, compressor oil and other lubricants, Preheating of lubrication oil and heavy fuel oil, Preheating of seawater for fresh water production, Heat recovery, Heat exchange to air-condition the passengers' cabins and freight spaces

Others: Turbine oil cooler, Chemical industry, district heating, district cooling, swimming pool heating, solar heating.



